

thermometers with electric contacts

all stainless steel construction

DS 4" (100 mm)



CE Compliance to requirements of
BT 2014/35/EU

These instruments are used to monitor the electrical activity of compressors, pumps, presses, hydraulic and pneumatic equipment, chemical and petrochemical plants. Contacts open or close the circuit according to the pointer position and they are adjustable over the whole range. Vibrations and pulsations effects on the instrument are drastically reduced by the liquid filling as well as those caused by a corrosive atmosphere making the gauge and the electric contacts longlasting and perform better. Also available with intrinsically safe inductive contacts.

6.TCE - Standard Model

Designation: EN 13190.
Indication ranges: -320...+1200 °F (-200...+600 °C).
Measuring ranges: -280...+1100 °F (-170...+500 °C).
Mechanical contact: sliding contact, magnetic snap-action, electronic, inductive.
Accuracy class: 1 as per EN 13190, measuring range.
Overtemperature: not suitable.
Ambient temperature: -13...+149 °F (-25...+65 °C).
Max working pressure: 360 psi - 25 bar (without thermowell).
Protection degree: IP 55 as per EN 60529/IEC 529.
Process connection: AISI 316 st.st.
Bulb: AISI 316 st.st. \varnothing 0.31-0.37-0.45" (8-9,5-11,5 mm), with rigid extension \varnothing 0.31" (8 mm)
Immersion length of the bulb with rigid extension "S": **S22** - \varnothing 0.31" (8 mm) = 5.63"...36.37" (143...1000 mm);
S21 - \varnothing 0.38" (9,6 mm) = 4.41"...36.37" (112...1000 mm);
S20 - \varnothing 0.45" (11,5 mm) = 3.35"...36.37" (85...1000 mm).
Measuring element: inert gas filled expansion system.
Case: stainless steel.

Ring: stainless steel bayonet lock.
Window: plexiglas.
Movement: stainless steel.
Internal compensation device: by a bimetallic linkage.
Dial: aluminium, white with black markings.
Pointer: adjustable, aluminium, black.

6.TCE...R13 - Filled Model

Indication ranges: -40...+500 °F (-40...+250 °C).
Measuring ranges: -20...+425 °F (-30...+220 °C).
Mechanical contact: magnetic snap-action, electronic, inductive.
Accuracy class: 2 as per EN 13190, measuring range.
Filling liquids: silicon oil.
Protection: IP 65 as per EN 60529/IEC 529.
Other features: as Standard Model.

(1) Instruments accuracy may be affected by extra electric mechanical contacts, if added: 1% accuracy turns to be 1,5%, 1,6% turns to be 2,4% etc. (add 50% of the instrument accuracy; in case of magnetically assisted type contact, this value can't be added within $\pm 5\%$ of setting point).

thermometres with electric contacts

all stainless steel construction, DS 4" (100mm)

TCE

RB2 - 04/13

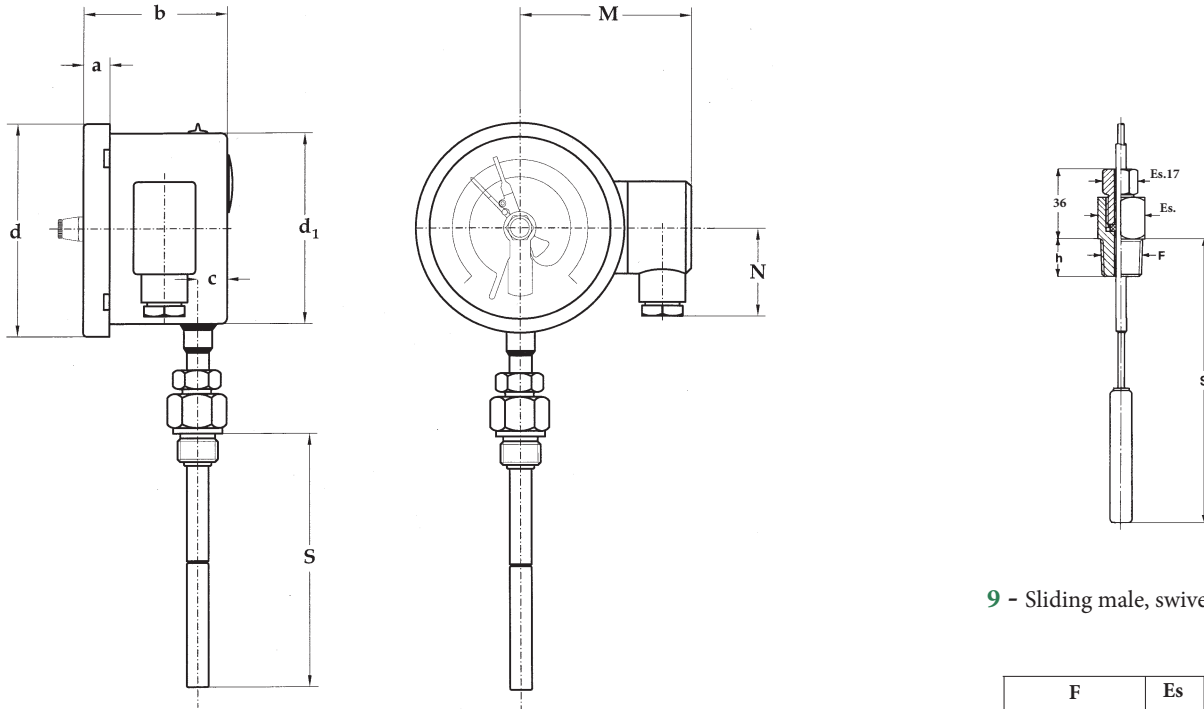

1 - Lower connection

DS	a	b (1)	d	d ₁	M	N
4" (100)	0.51" (13)	2.81/2.85" (71,5/82,5)	4.41" (112)	3.98" (101)	3.54" (90)	1.81" (46)

dimensions : inches (mm)

9 - Sliding male, swivel nut

F	Es	h
41M G 1/2 A	0.87" (22)	0.55" (14)
43M 1/2-14 NPT	0.87" (22)	0.67" (17)
51M G 3/4 A	1.06" (27)	0.63" (16)
53M 3/4-14 NPT	1.06" (27)	0.67" (17)

CONTACT TYPE (1)

MODEL	Standard			Filled		
	Sliding contact, electronic			Magnetic snap-action contact, electronic		
Contact type	Sliding contact, electronic			Magnetic snap-action contact, electronic		
Contact number	1	2	2 independent	1	2	2 independent
Junction box	3 poles + GND	3 poles + GND	6 poles + GND	6 poles + GND	6 poles + GND	6 poles + GND
ø exit cables: inches (mm)	0,23...0,35 (6...9)	0,23...0,35 (6...9)	0,27...0,51 (7...13)	0,27...0,51 (7...13)	0,27...0,51 (7...13)	0,27...0,51 (7...13)
Minimum range	140°F (60°C)	140°F (60°C)	140°F (60°C)	140°F (60°C)	140°F (60°C)	140°F (60°C)

(1) Functional characteristics, electric diagrams and contact types are available on data-sheets : "ELECTRIC CONTACTS", "ELECTRONIC CONTACTS"

OPTIONS

R13 - Filling liquid: silicon oil, for temperature range ≤ +500 °F (250 °C)
ATEX version, with intrinsic safety inductive contact (1)

(1) See ATEX data-sheet for technical details

"HOW TO ORDER" SEQUENCE

Section / Model / Mounting / Connection type / Diameter / Range / Process connection / Bulb / Options
6 TCE 1 9 E 41M, 43M 520...22 R13 51M, 53M

Copyright © Nuova Fima srl. All rights reserved. Any part of this publication should not be reproduced without a written Nuova Fima's srl approval

NUOVA FIMA USA Inc.
 www.nuovafima.com - e-mail: infousa@nuovafima.com
 4123 Hollister, Suite G - TX 77080 Houston
 TEL. +1 713.690.9800 - FAX +1 713.690.9803

NUOVA FIMA srl
 www.nuovafima.com - e-mail: info@nuovafima.com
 P.O. BOX 58 - VIA C. BATTISTI 59 - 28045 INVORIO (NO) ITALY
 TEL. +39 0322 253200 - FAX +39 0322 253232

