

pressure gauges with electric contacts all stainless steel execution DS 4", 6" (100-150 mm)



CE Compliance to requirements of
LVD 2014/35/EU - PED 2014/68/EU

EAC

The electrical and inductive contacts pressure gauges are provided with free contacts in air which open and close electric circuits according to the position of the pointer. If combined with Bourdon tube pressure gauges, bellows, diaphragms and thermometers designed by NUOVA FIMA, they turn into pressure or temperature switches.

1.M8.1 - Standard Model

Ranges: from 0...15 to 0...20000 psi (from 0...1 to 0...1600 bar or equivalent units).

Mechanical contact: sliding contact, magnetic snap-action, electronic, inductive.

Accuracy: $\pm 1,0\%$ as per EN 837-1 - DIN 16085 (1).

Ambient temperature: -13...+149 °F (-25...+65 °C).

Process fluid temperature: max +212°F (+100 °C).

Working pressure: max 75% of the full scale value.

Over pressure: not suitable.

Protection: IP 44 as per EN 60529/IEC 529.

Socket material: AISI316L st.st.

Elastic element: AISI316L st.st.

Case: stainless steel.

Ring: stainless steel, bayonet lock.

Window: plastic.

Movement: stainless steel.

Dial: aluminium, white with black markings.

Pointer: adjustable, aluminium, black

(1) Adding mechanical electric contacts may affect the accuracy of the instruments so that 1% becomes 1,5%, 1,6% becomes 2,4% etc. (add the 50% of accuracy; if the contact is a magnetically assisted type, this value cannot be added within the $\pm 5\%$ of setting point).

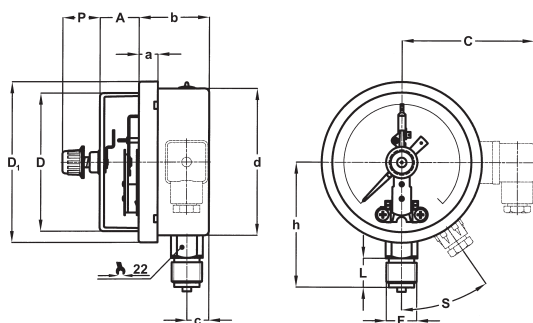

A - LOWER CONNECTION

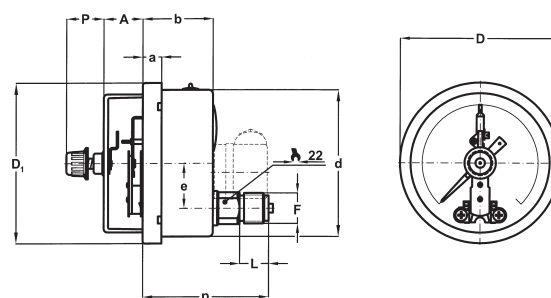

D - BACK CONNECTION

DS	Mounting	F	A (1)	a	b	C	c	D	D ₁	d	e	h	L	P	p	S
E 4" (100)	Lower	41M G 1/2 A	1.06"...2.36"	0.51"	1.91"	2.72"	0.59" (15)	3.74"	4.35"	3.98"		3.39" (86)	0.79"	0.77"		35°
	Back	43M 1/2-14 NPT	(27...60)	(13)	(48,5)	(69)		(95)	(110,6)	(101)	1.22" (31)		(20)	(19,6)	3.54" (90)	
G 6" (150)	Lower	41M G 1/2 A	1.02"...2.32"	0.59"	1.99"	2.72"	0.61" (15,5)	5.55"	6.34"	5.89		4.61" (117)	0.79"	0.77"		35°
	Back	43M 1/2-14 NPT	(26...59)	(15)	(50,5)	(69)		(141)	(161)	(149,6)	1.22" (31)		(20)	(19,6)	3.50" (89)	

dimensions : inches (mm)

(1) dimensions for single/double contact;

CONTACT TYPE (1)

MODEL	DS 4" (100 mm)			DS 6" (150 mm)		
	Sliding and magnetic snap-action contact					
Contact type	Sliding and magnetic snap-action contact					
Contact number	1	2	2 independent	1	2	2 independent
Junction box ø exit cables: inches (mm)	3 poles + GND 0,23...0,35 (6...9)	3 poles + GND 0,23...0,35 (6...9)		3 poles + GND 0,23...0,35 (6...9)	3 poles + GND 0,23...0,35 (6...9)	
Cable exit ø cable: inches (mm)	2 poles + GND (2) 0,19 (4,8)	3 poles + GND (2) 0,23 (6)	4 poles + 1 0,27 (7)	2 poles + GND (2) 0,19 (4,8)	3 poles + GND (2) 0,23 (6)	4 poles + 1 0,27 (7)
Minimum range	15 psi (1bar)	23 psi (1,6 bar)	23 psi (1,6 bar)	15 psi (1bar)	23 psi (1,6 bar)	23 psi (1,6 bar)

(1) Functional characteristics, electric diagrams and contact types are available on data-sheets : "ELECTRIC CONTACTS".

(2) U-clamp back connection pressure gauges only.

OPTIONS

B	- "U" - clamp, for back connection pressure gauges
C	- Back flange, for lower connection pressure gauges
E	- Front flange, for back connection pressure gauges
CH1	- Removable key, protection IP 55

"HOW TO ORDER" SEQUENCE

Section / Model / Case / Mounting / Diameter / Range / Process connection / Electric contact / Options

1 M8 1 A E 41M 01S...M9D B, C, E
D G 43M CH1

Copyright © Nuova Fima srl. All rights reserved. Any part of this publication should not be reproduced without a written Nuova Fima's srl approval