

Instrument Pipe Fittings

316 stainless steel ranging from 1/8 to 1 inch sizes



DFC
Daghigh Farayand Control
VEE-LOK[®]
valve & fitting

www.veelok.com

Instrument Pipe Fittings

Features

- Used for process control and instrumentation connections.
- Precision machined from forgings for shaped fittings and from bar stock for straight connectors.
- Size ranges from 1/8"NPT through 1"NPT.
- NPT threads are based on requirements of ANSI B1.20.1.
- A pipe thread sealant or PTFE tape are always used when assembling tapered thread.
- Male threads are capped for protection.

Pressure Ratings

Size Designator	NPT Size	316 Stainless steel			
		Male		Female	
		psi	bar	psi	bar
2	1/8"	10000	689	6500	447
4	1/4"	8000	551	6600	454
6	3/8"	7800	537	5300	365
8	1/2"	7700	530	4900	337
12	3/4"	7300	502	4600	316
16	1"	5300	365	4400	303

- Working pressures calculated are for reference only.
- Ratings are based on ASME Code for Pressure Piping B31.3 with allowable stress value 20,000 psi (1378 bar) and pressure ratings are calculated in accordance with Power Piping Code ANSI B31.1
- Pressure ratings of female threads are lower than male threads due to larger outer diameter.

Temperature Ratings

System temperatures may be limited by the thread sealant or PTFE tape to 450°F (232°C).

Material	Maximum Temperature °F (°C)
316 stainless steel	1000°F (537°C)

Ordering Information

Example :

HRN	8	—	2
Name of fitting	1 st End 1/2"NPT male pipe		2 nd End 1/8"NPT male pipe

- Pipe size are designated by the number of sixteenths of an inch.

For example, 1/2"NPT =8/16=8

- All pipe threads are NPT unless otherwise designated with BSPT or BSPP.

Visual Index

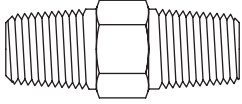
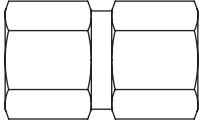
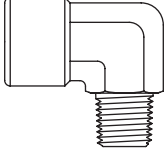
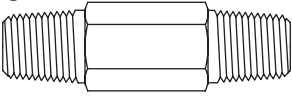
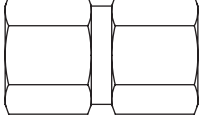
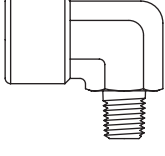
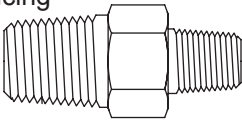
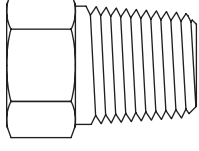
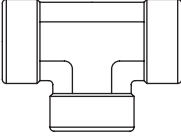
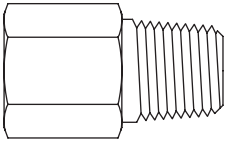
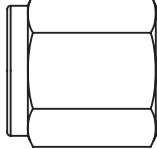
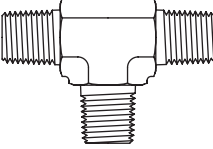
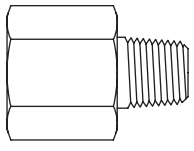
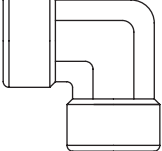
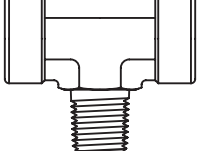
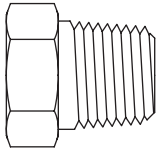
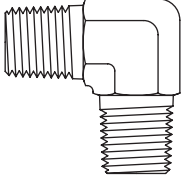
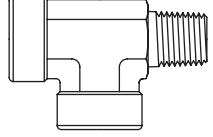
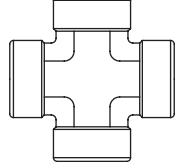
<p>HN Hex Nipple</p> <p>3</p> 	<p>HC Hex Coupling</p> <p>5</p> 	<p>E_MF Street Elbow</p> <p>6</p> 
<p>HLN Hex Long Nipple</p> <p>3</p> 	<p>HRC Hex Reducing Coupling</p> <p>5</p> 	<p>E_M_F Reducing Street Elbow</p> <p>6</p> 
<p>HRN Hex Reducing Nipple</p> <p>3</p> 	<p>PP Pipe Plug</p> <p>5</p> 	<p>T_F Female Tee</p> <p>7</p> 
<p>A Adapter</p> <p>4</p> 	<p>PC Pipe Cap</p> <p>5</p> 	<p>T_M Male Tee</p> <p>7</p> 
<p>RA Reducing Adapter</p> <p>4</p> 	<p>E_F Female Elbow</p> <p>6</p> 	<p>T_FMF Male Branch Tee</p> <p>7</p> 
<p>RB Reducing Bushing</p> <p>4</p> 	<p>E_M Male Elbow</p> <p>6</p> 	<p>T_MFF Street Tee</p> <p>8</p> 
		<p>C_F Cross</p> <p>8</p> 

HEX NIPPLE

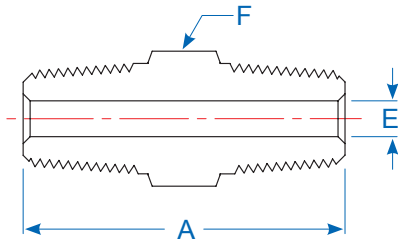

HEX REDUCING NIPPLE

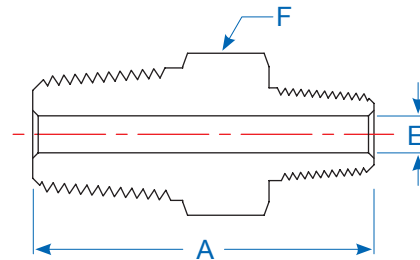

Male NPT Threads

PIPE THREAD	PART NO.	Dimensions (inch)		
		A	E	F
1/8	HN2	1.01	0.19	7/16
1/4	HN4	1.40	0.28	9/16
3/8	HN6	1.43	0.38	11/16
1/2	HN8	1.84	0.47	7/8
3/4	HN12	1.84	0.62	1-1/16
1	HN16	2.32	0.88	1-3/8

Male NPT Threads

PIPE THREAD	MALE THREAD	PART NO.	Dimensions (inch)		
			A	E	F
1/4	1/8	HRN4-2	1.22	0.19	9/16
3/8	1/8	HRN6-2	1.25	0.19	11/16
3/8	1/4	HRN6-4	1.43	0.28	11/16
1/2	1/8	HRN8-2	1.41	0.19	7/8
1/2	1/4	HRN8-4	1.65	0.28	7/8
1/2	3/8	HRN8-6	1.65	0.38	7/8
3/4	1/4	HRN12-4	1.65	0.28	1-1/16
3/4	1/2	HRN12-8	1.84	0.47	1-1/16
1	1/2	HRN16-8	2.13	0.47	1-3/8
1	3/4	HRN16-12	2.13	0.62	1-3/8

HEX LONG NIPPLE

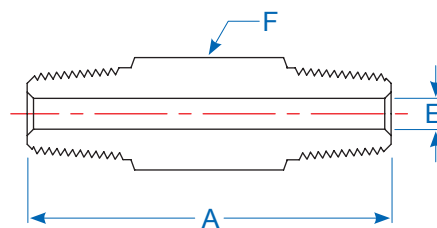

Male NPT Threads

PIPE THREAD	PART NO.	Available Lengths, inch					Dimensions (inch)	
		A					E	F
		1.50	2.00	2.50	3.00	4.00		
1/8	HLN2	V	V	V	V	—	0.19	7/16
1/4	HLN4	V	V	V	V	V	0.28	9/16
3/8	HLN6	V	V	V	V	V	0.38	11/16
1/2	HLN8	—	V	—	V	V	0.47	7/8
3/4	HLN12	—	V	—	V	V	0.62	1-1/16
1	HLN16	—	—	—	V	V	0.88	1-3/8

Dimensions for reference only, subject to change

ADAPTER

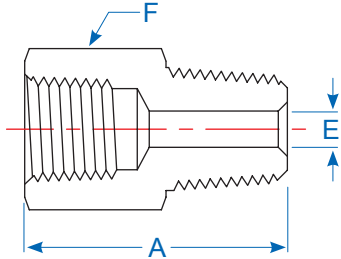

Female to Male NPT Threads

PIPE THREAD	PART NO.	Dimensions (inch)		
		A	E	F
1/8	A2	1.10	0.19	9/16
1/4	A4	1.40	0.28	3/4
3/8	A6	1.51	0.38	7/8
1/2	A8	1.85	0.47	1-1/16
3/4	A12	1.85	0.62	1-3/8
1	A16	2.20	0.88	1-5/8

REDUCING ADAPTER

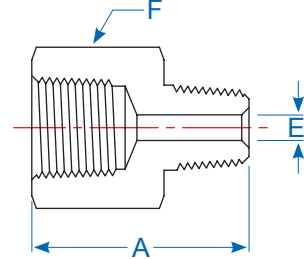

Female to Male NPT Threads

FEMALE THREAD	MALE THREAD	PART NO.	Dimensions (inch)		
			A	E	F
1/4	1/8	RA4-2	1.21	0.19	3/4
3/8	1/8	RA6-2	1.25	0.19	7/8
3/8	1/4	RA6-4	1.50	0.28	7/8
1/2	1/8	RA8-2	1.49	0.19	1-1/16
1/2	1/4	RA8-4	1.66	0.28	1-1/16
1/2	3/8	RA8-6	1.66	0.38	1-1/16
3/4	1/4	RA12-4	1.66	0.28	1-3/8
3/4	3/8	RA12-6	1.66	0.38	1-3/8
3/4	1/2	RA12-8	1.85	0.47	1-3/8
1	1/4	RA16-4	1.92	0.28	1-5/8
1	1/2	RA16-8	2.16	0.47	1-5/8
1	3/4	RA16-12	2.17	0.62	1-5/8

REDUCING BUSHING

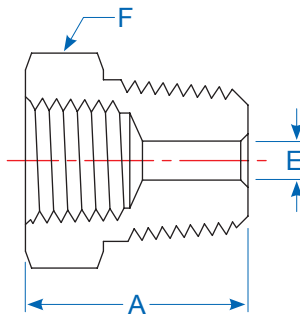

Male to Female NPT Threads

MALE THREAD	FEMALE THREAD	PART NO.	Dimensions (inch)		
			A	E	F
1/4	1/8	RB4-2	1.06	0.28	9/16
3/8	1/8	RB6-2	0.86	0.34	11/16
3/8	1/4	RB6-4	1.19	0.38	3/4
1/2	1/8	RB8-2	1.08	0.34	7/8
1/2	1/4	RB8-4	1.08	0.45	7/8
1/2	3/8	RB8-6	1.41	0.47	7/8
3/4	1/4	RB12-4	1.13	0.45	1-1/16

MALE THREAD	FEMALE THREAD	PART NO.	Dimensions (inch)		
			A	E	F
3/4	3/8	RB12-6	1.13	0.59	1-1/16
3/4	1/2	RB12-8	1.63	0.62	1-1/16
1	1/4	RB16-4	1.37	0.45	1-3/8
1	3/8	RB16-6	1.37	0.59	1-3/8
1	1/2	RB16-8	1.37	0.73	1-3/8
1	3/4	RB16-12	1.85	0.88	1-3/8

Dimensions for reference only, subject to change

HEX COUPLING

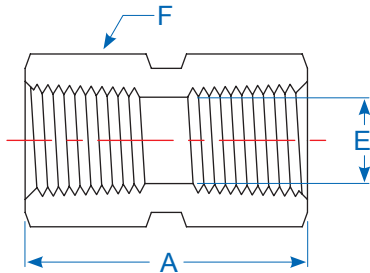

HEX REDUCING COUPLING

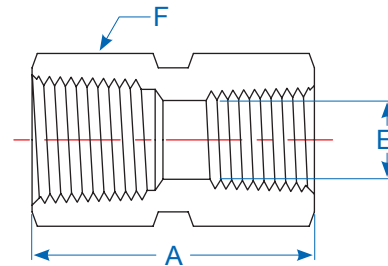

Female NPT Threads

PIPE THREAD	PART NO.	Dimensions (inch)		
		A	E	F
1/8	HC2	0.81	0.34	9/16
1/4	HC4	1.19	0.45	3/4
3/8	HC6	1.31	0.59	7/8
1/2	HC8	1.56	0.73	1-1/16
3/4	HC12	1.62	0.94	1-3/8
1	HC16	2.00	1.17	1-5/8

Female NPT Threads

FEMALE THREAD	FEMALE THREAD	PART NO.	Dimensions (inch)		
			A	E	F
1/4	1/8	HRC4-2	1.21	0.34	3/4
3/8	1/4	HRC6-4	1.31	0.45	7/8
1/2	1/8	HRC8-2	1.56	0.34	1-1/16
1/2	1/4	HRC8-4	1.69	0.45	1-1/16
1/2	3/8	HRC8-6	1.75	0.59	1-1/16
3/4	1/4	HRC12-4	1.81	0.45	1-3/8
3/4	1/2	HRC12-8	1.88	0.73	1-3/8
1	1/2	HRC16-8	2.19	0.73	1-5/8
1	3/4	HRC16-12	2.25	0.94	1-5/8

PIPE PLUG

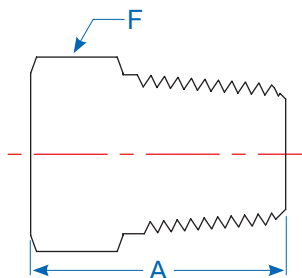

PIPE CAP

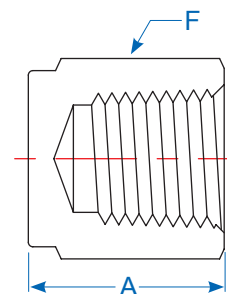

Male NPT Threads

MALE THREAD	PART NO.	Dimensions (inch)	
		A	F
1/8	PP2	0.63	7/16
1/4	PP4	0.80	9/16
3/8	PP6	0.80	11/16
1/2	PP8	1.05	7/8
3/4	PP12	1.13	1-1/16
1	PP16	1.32	1-3/8

Female NPT Threads

FEMALE THREAD	PART NO.	Dimensions (inch)	
		A	F
1/8	PC2	0.71	9/16
1/4	PC4	0.87	3/4
3/8	PC6	0.91	7/8
1/2	PC8	1.18	1-1/16
3/4	PC12	1.18	1-3/8
1	PC16	1.42	1-5/8

Dimensions for reference only, subject to change

FEMALE ELBOW

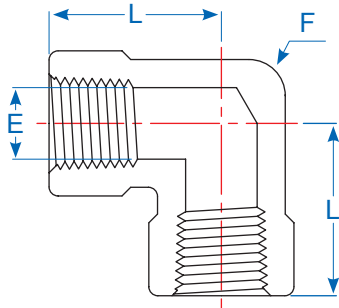

MALE ELBOW

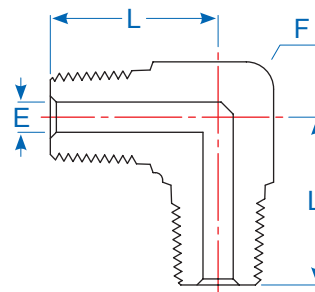

Female NPT Threads

FEMALE THREAD	PART NO.	Dimensions (inch)		
		L	E	F
1/8	E2F	0.94	0.19	9/16
1/4	E4F	1.07	0.28	13/16
3/8	E6F	1.37	0.38	7/8
1/2	E8F	1.43	0.47	1-1/16
3/4	E12F	1.53	0.61	1-3/8
1	E16F	2.04	0.86	1-11/16

Male NPT Threads

MALE THREAD	PART NO.	Dimensions (inch)		
		L	E	F
1/8	E2M	0.69	0.19	1/2
1/4	E4M	0.98	0.28	5/8
3/8	E6M	1.04	0.38	11/16
1/2	E8M	1.39	0.47	7/8
3/4	E12M	1.44	0.61	1-1/16
1	E16M	1.90	0.86	1-3/8

STREET ELBOW

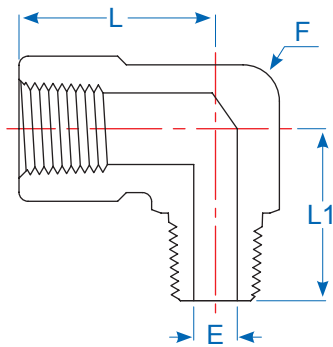

REDUCING STREET ELBOW

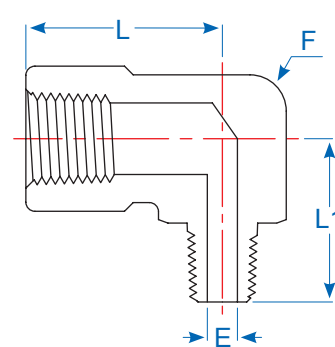

Female to Male NPT

FEMALE THREAD	MALE THREAD	PART NO.	Dimensions (inch)			
			L	L1	E	F
1/8	1/8	E2MF	0.97	0.77	0.19	1/2
1/4	1/4	E4MF	1.14	1.13	0.28	11/16
3/8	3/8	E6MF	1.33	1.18	0.38	13/16
1/2	1/2	E8MF	1.43	1.45	0.47	1-1/16
3/4	3/4	E12MF	1.53	1.81	0.61	1-3/8
1	1	E16MF	2.03	2.06	0.86	1-11/16

Female to Male NPT

FEMALE THREAD	MALE THREAD	PART NO.	Dimensions (inch)			
			L	L1	E	F
1/4	1/8	E2M4F	1.14	0.95	0.19	11/16
3/8	1/4	E4M6F	1.33	1.18	0.28	13/16
1/2	1/4	E4M8F	1.44	1.31	0.28	1
1/2	3/8	E6M8F	1.44	1.31	0.38	1

Dimensions for reference only, subject to change

FEMALE TEE

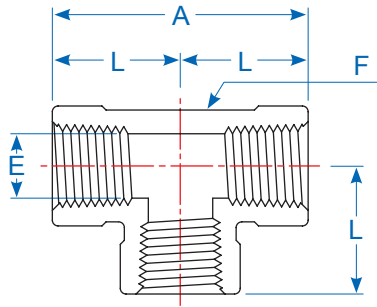

MALE TEE

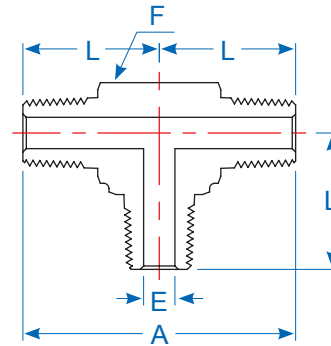

Female NPT Threads

FEMALE THREAD	PART NO.	Dimensions (inch)			
		A	L	E	F
1/8	T2F	1.85	0.93	0.34	5/8
1/4	T4F	2.15	1.07	0.44	13/16
3/8	T6F	2.75	1.37	0.57	7/8
1/2	T8F	2.88	1.44	0.70	1-1/16
3/4	T12F	3.74	1.87	0.86	1-3/8
1	T16F	4.07	2.03	1.10	1-11/16

Male NPT Threads

MALE THREAD	PART NO.	Dimensions (inch)			
		A	L	E	F
1/8	T2M	1.39	0.69	0.19	1/2
1/4	T4M	1.95	0.97	0.28	9/16
3/8	T6M	2.08	1.04	0.38	11/16
1/2	T8M	2.72	1.36	0.47	7/8
3/4	T12M	2.91	1.45	0.61	1-1/16
1	T16M	3.78	1.89	0.86	1-3/8

MALE BRANCH TEE

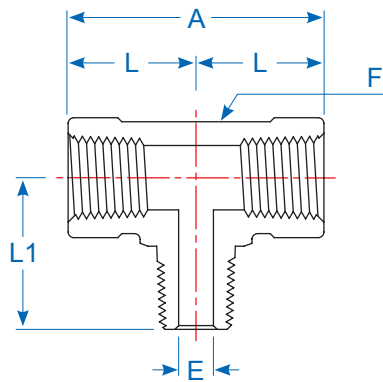

Male & Female NPT Threads

MALE THREAD	FEMALE THREAD	PART NO.	Dimensions (inch)				
			A	L	L1	E	F
1/8	1/8	T2FMF	1.85	0.93	0.93	0.19	9/16
1/4	1/4	T4FMF	2.15	1.07	1.14	0.28	13/16
3/8	3/8	T6FMF	2.75	1.37	1.22	0.38	7/8
1/2	1/2	T8FMF	2.87	1.43	1.45	0.47	1-1/16
3/4	3/4	T12FMF	3.66	1.83	1.87	0.61	1-3/8
1	1	T16FMF	4.07	2.03	2.06	0.86	1-11/16

Dimensions for reference only, subject to change

STREET TEE

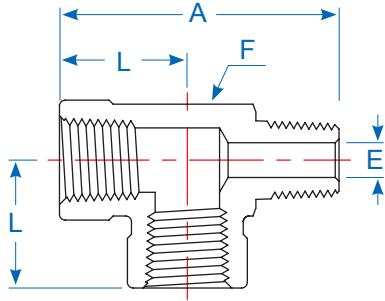

CROSS

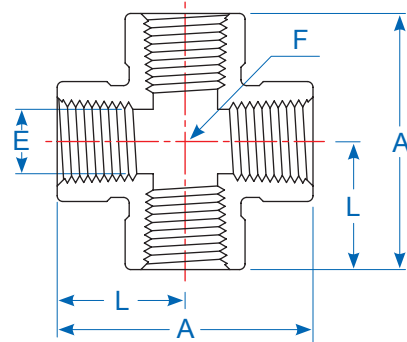

Male & Female NPT Threads

FEMALE THREAD	MALE THREAD	PART NO.	Dimensions (inch)			
			A	L	E	F
1/8	1/8	T2MFF	1.88	0.94	0.19	9/16
1/4	1/4	T4MFF	2.22	1.07	0.28	13/16
3/8	3/8	T6MFF	2.59	1.37	0.38	7/8
1/2	1/2	T8MFF	2.89	1.43	0.47	1-1/16
3/4	3/4	T12MFF	3.70	1.83	0.61	1-3/8
1	1	T16MFF	4.10	2.03	0.86	1-11/16

Female NPT Threads

FEMALE THREAD	PART NO.	Dimensions (inch)			
		A	L	E	F
1/8	C2F	1.77	0.88	0.34	5/8
1/4	C4F	2.12	1.06	0.44	13/16
3/8	C6F	2.26	1.13	0.57	7/8
1/2	C8F	2.48	1.24	0.70	1-1/16
3/4	C12F	3.70	1.85	0.86	1-3/8
1	C16F	3.83	1.91	1.10	1-11/16

Dimensions for reference only, subject to change

Vertex Co., Ltd.

3F, No.3, Lane 551, Sec. 1, Wanshou Rd.,
Gueishan Township, Taoyuan County 33351,
Taiwan

Tel: +886 2 8200 3813

Fax: +886 2 8200 3817

vertex.jo@msa.hinet.net

