

sanitary pressure gauges

DS 2.5", 4" (63-100mm)



74-06

Autorization NO. 1599



These instruments are designed for Sanitary, Food Process and Pharmaceutical Industries in compliance with standard n.74-06 of 3-A (Sanitary Standards Symbol Administrative Council). The absence of interstices and the mirror finishing of the components assure the best hygiene level. The combination of pressure gauge and diaphragm seal allow to reduce the inner volumes and temperature error. To reduce the effects of severe working conditions like vibrations and pulsations, the instruments can be liquid-filled.

1.SP.2 - Liquid fillable

Design: 74-06 SSI; ASME B40.1

Ranges: from 0...15 psi to 0...600 psi; (from 0...1 bar to 0...40 bar or equivalent units).

Accuracy: grade A as per ASME B40.1 (2-1-2%) for DS 4" (100mm); grade B as per ASME B40.1 (3-2-3%) for DS 2.5" (63mm);

Ambient temperature: -13...+149 °F (-25...+65 °C).

Process temperature: -4...+212 °F (-20...+100 °C).

Max 284°F (140 °C) for 30 minutes during cleaning stage (C.I.P.)¹ and sterilization (S.I.P.)².

Working pressure (referred to the full scale value): max 75%.

Over pressure limit: not available.

Seal fill: mineral oil (FDA approved) for food service.

Protection degree: IP 67 as per EN 60529/IEC 529.

Process connection: AISI 316L st.st. with finishing Ra ≤0,76 µm (welded parts included), as per ASME BPE SF3.

Diaphragm: AISI 316L st.st. .

Welding: AISI 316L TIG.

Case: electro polished AISI 304 st.st.

Ring: polished AISI 304 st.st., crimped.

Window: plastic on DS 2.5" (63mm); tempered glass on DS 4" (100 mm).

Dial: aluminium, white with black markings.

Pointer: aluminium black anodized.

1.SP.3 - Liquid filled

Case fill: glycerine 99,5% (USP, E.P. e F.U.) for food service.

Ambient temperature: +32...+149 °F (0...+65 °C).

Other features: as standard model.

1.SP.2.A.E.ATV - Autoclavable

This version can be autoclaved and sterilized at a max temperature of 304°F (150 °C) for 1 hour.

Window: Polysulfone.

Gasket: silicon rubber.

Blow out vent and filling plug: VITON.

Other features: as standard model.

1) C.I.P. = Cleaned In Place

2) S.I.P. = Steamed In Place - available for ranges > 1bar when steam pressure does not exceed the max admissible pressure on the connected instrument

sanitary pressure gauges

DS 2.5", 4" (63-100mm)

SP

RC5-02/16

www.nuovafima.com

IN ORDER TO IMPROVE THEIR PRODUCTION, MESSRS. NUOVA FIMA RESERVE THE RIGHT TO THEMSELVES TO MAKE ALL THE MODIFICATIONS THAT THEY DEEM INDISPENSABLE AT ANY TIME. UPDATED DATA SHEETS ARE AVAILABLE ON SITE: www.nuovafima.com

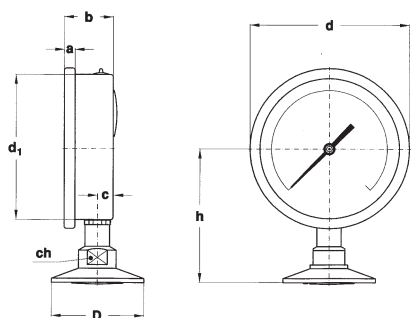

A - LOWER CONNECTION

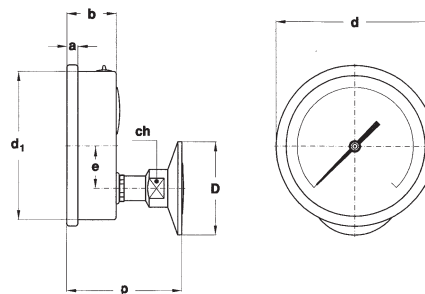

**D - BACK CONNECTION,
FOR DS 4" (100mm) ONLY**

DS	AT- 1"1/2	D BT- 2"	a	b	c	d	d ₁	e	h	p	ch	Weight (1)
C 2.5" (63 mm)	1.98"	2.51"	0.21"	1.10"	0.39"	2.67"	2.46"		3.11"		0.86"	0.61 lbs
E 4" (100 mm)	1.98"	2.51"	0.29"	1.33"	0.43"	4.33"	0.39"	0.73"	3.50"	2.99"	0.86"	0.92 lbs

(dimensioni : inches)

(1) add 0.26 lbs (0,12 kg) for DS 2.5" (63 mm) and 0.66 lbs (0,30 kg) for DS 4" (100 mm), when filled

RANGES - "C" = DS 2.5" (63mm); "E" = DS 4" (100mm).

PRESSURE

TAB. 1

RANGE	bar
0...1 (1)	E
0...1,6 (1)	E
0...2,5	C-E
0...4	C-E
0...6	C-E
0...10	C-E
0...16	C-E
0...25	C-E
0...40	C-E

TAB. 2

RANGE	psi ext. bar int.
0...15 (1)	E
0...30	C-E
0...60	C-E
0...100	C-E
0...160	C-E
0...200	C-E
0...300	C-E
0...400	C-E
0...600	C-E

VACUUM & COMPOUND

TAB. 3

RANGE	bar
-1...0 (1)	E
-1...0,6 (1)	E
-1...1,5	C-E
-1...3	C-E
-1...5	C-E
-1...9	C-E
-1...15	C-E

TAB. 4

RANGE (2)	psi ext. bar int.
-30...0 (1)	E
-30...15 (1)	E
-30...30	C-E
-30...60	C-E
-30...100	C-E
-30...150	C-E
-30...300	C-E

(1) available only for 2" CLAMP connection

(1) available only for 2" CLAMP connection

(2) vacuum unit of measurement: "inHg"

FINISHING

0 - Ra ≤ 0,76 μm, as per ASME BPE SF1	(1)
A - Ra ≤ 0,51 μm, as per ASME BPE SF1	(1)
B - Ra ≤ 0,38 μm, as per ASME BPE SF4 - electropolished	(1)

(1) welded parts included

OPTIONS

K16 - Accuracy ± 1,6%
TPC - Polycarbonate window

"HOW TO ORDER" SEQUENCE

Section / Model / Case / Mounting / Diameter / Special Version / Range / Process connection / Finishing / Options

1 SP 2 A C ATV AT- 0 K16...TPC
3 D E BT- A B

